



# cebilon

## dflow

*Reverse Osmosis System  
User Manual*



**DIRECT  
FLOW**

**CE**

Member, Water Quality Association



## Dear Customer,

Thank you for choosing our product. We want Cebilon Reverse Osmosis System, manufactured in modern facilities with high quality standards to provide you with the best efficiency. Therefore, please read the entire user manual carefully and keep it as a reference.



Member, Water Quality Association

# Table of Contents

FIELD OF USE	3
TECHNICAL SPECIFICATIONS	3
OPERATING PRINCIPLE	3
PARTS AND FUNCTIONS	4
INSTALLATION SCHEME	5
WATER CONNECTION	6
INSTALLING THE FAUCET	6
WASTE WATER CONNECTION	7
PRE-TESTS	7
POINTS FOR ANNENTION	7
MEINTENANCE	8
RECOMMENDED FILTER REPLACEMENT PERIODS	8
TROUBLESHOOTING	9
DIGITAL SCREEN FUNCTIONS	10



## Field of use

This appliance is used to obtain drinking water from the mains water that have passed through the municipal treatment processes. This water should be microbiologically safe, subjected to the necessary disinfection. If the parameters of the inlet water are within the following ranges efficient operation of the appliance is ensured. Systems designed differently for waters such as sea water, well water, muddy water etc. with a very high TDS value are also available.

### INLET WATER FEATURES

TEMPERATURE	5 °C - 38 °C / (38 °F - 100 °F)
OPERATING PRESSURE	40 psi-145 psi / (2,8 bar-10 bar) / (275 kPa - 1.000 kPa)
pH RANGE	3-11
MAXIMUM FE	0,2 (ppm=mg/L)
MAXIMUM TDS	1.250 (ppm=mg/L)
TURBIDITY	5 NTU
HARDNESS	17 °Fr-10 °dH - 170 mg/L CaCO3

## Technical Specifications

- Do not use this system with any water that is microbiologically unsafe, that does not have adequate disinfection before or after operation or that of the quality is unknown.
- Cebilon Dflow contains critical components that are required to be replaced periodically to purify the total dissolved solid materials (TDS) efficiently. To check the efficiency of the system, water from the appliance must be periodically tested.

DAILY CAPACITY	800 gpd (3.000 L/day)
PURIFICATION RATE	%85-%98
EFFICIENCY RATIO	% 54
RECOVERY RATING	% 55
POWER SUPPLY PUMP	36 V DC
PUMP PRESSURE	110 psi-150 psi (758-1.034 kPa)
BOX SIZE	215x585x395 mm
PRODUCT SIZE	210x450x375 mm
GROSS WEIGHT	11 kg

## Operating principle

The first filter of the system is the 5-micron sediment filter where the solid particles are retained. The water from the sediment filter is passed through the carbon filter. Granular Active Carbon (GAC) filter retains organic matter especially free chlorine and eliminates unwanted odors, carbon and other particles that may escape from the filter, is passed through the 1 micron Sediment Filter and it is ensured that the pre-membrane filter is even more suitable. This is also a factor affecting the life of the membrane. The water cleaned in three pre-filters, solid ions dissolved in the membrane that is the basis of the RO water treatment system, small particles, bacteria, viruses are retained to a large extent and given to the waste water. Among these ions are many ions such as heavy metals, sodium, lead, arsenic, nitrate, asbestos, etc. While the waste water containing the undesirable substances are discharged from one line of the membrane running with cross-flow method, water received from the other line of the cross-flow is collected in a pressurized tank. The amount of waste water should always be more than the clean water so that the membrane works in a healthy way and has a long life. Through the ready the water in the tank, water is supplied faster. Through the mineralized pos carbon filter, which filters out unpleasant odors and tastes that may have been left in the water and adds useful minerals to the water.

# Parts and functions

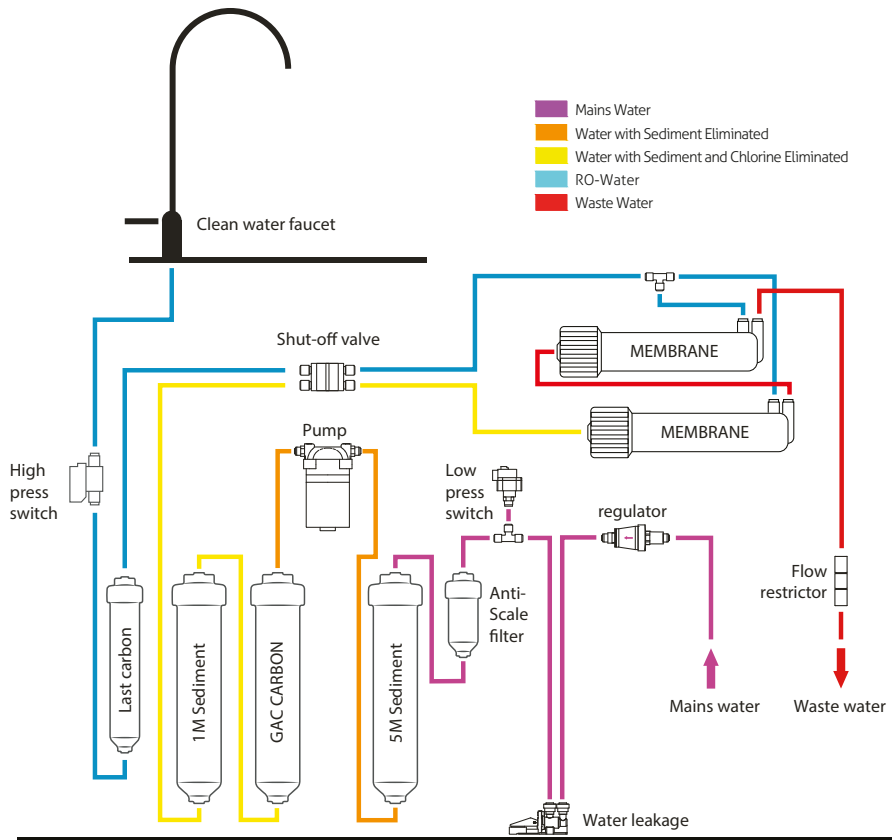

Figure 1

**Regulator:** In places where municipal water pressure is high, the regulator restricts water pressure, limits it, and stabilizes it to protect the device.

**Water Leakage Stopper:** Mechanically shuts off the water inlet in case of a water leak.

**Low Pressure Switch:** Prevents unnecessary operation of the pump when there is no water or when the pressure drops below 0.2 bar (3 psi).

**Anti-Scale Filter:** Used to prevent lime in water, enhancing water quality.

**5 Micron Sediment Filter:** Captures floating substances and particles in water to clarify it to the 5-micron level.

**Pressure Pump:** Adjusts the pressure of water passing through pre-filtration to the level required for membrane operation.

**Carbon Filter:** Removes free chlorine, organic matter, and unwanted odors.

**1 Micron Sediment Filter:** Captures floating substances and particles in water to clarify it to the 1-micron level.

**Mineral Carbon Filter:** Enriches and regulates pH of clean water from the membrane before it flows from the tap.

**Shut-off Valve:** Controls water flow; cuts off water flow when tank pressure reaches a certain level of membrane inlet pressure.

**High Pressure Switch:** Stops the pump when pressure in the clean water line reaches 2.6 bar (38 psi).

**Restrictor:** Restricts flow to create necessary pressure for membrane separation process; located on the line where waste water is discharged.

**Clean Water Faucet:** Faucet from which clean water is obtained.

**Power Adapter:** Power source for the pump; converts mains voltage to 36 V DC.

**Digital Display:** Indicates filter lifespan.

**Membrane Filter:** Where dissolved substances in water are purified, typically achieving 85% to 98% purification.

# Installation scheme

Please make sure that, flushing the filters, before you start using the device. For filters flushing, you can follow the instructions below.

## Warning!

- 1- Measures should be taken against freezing. (To take precautions against freezing is the customer's responsibility)
- 2- Waste water should not be interfered with.
- 3- When muddy (clay) water comes from the mains, close the water inlet of the appliance.
- 4- If a water supply other than the mains will be used, you must receive a drinking water report from relevant institutions.
- 5- If it is a water source other than the mains water, make sure that the disinfection process is performed.
- 6- Filters are considered as supplies and are outside the scope of warranty.
- 7- Free chlorine in water may cause membrane filter in the system to deteriorate.

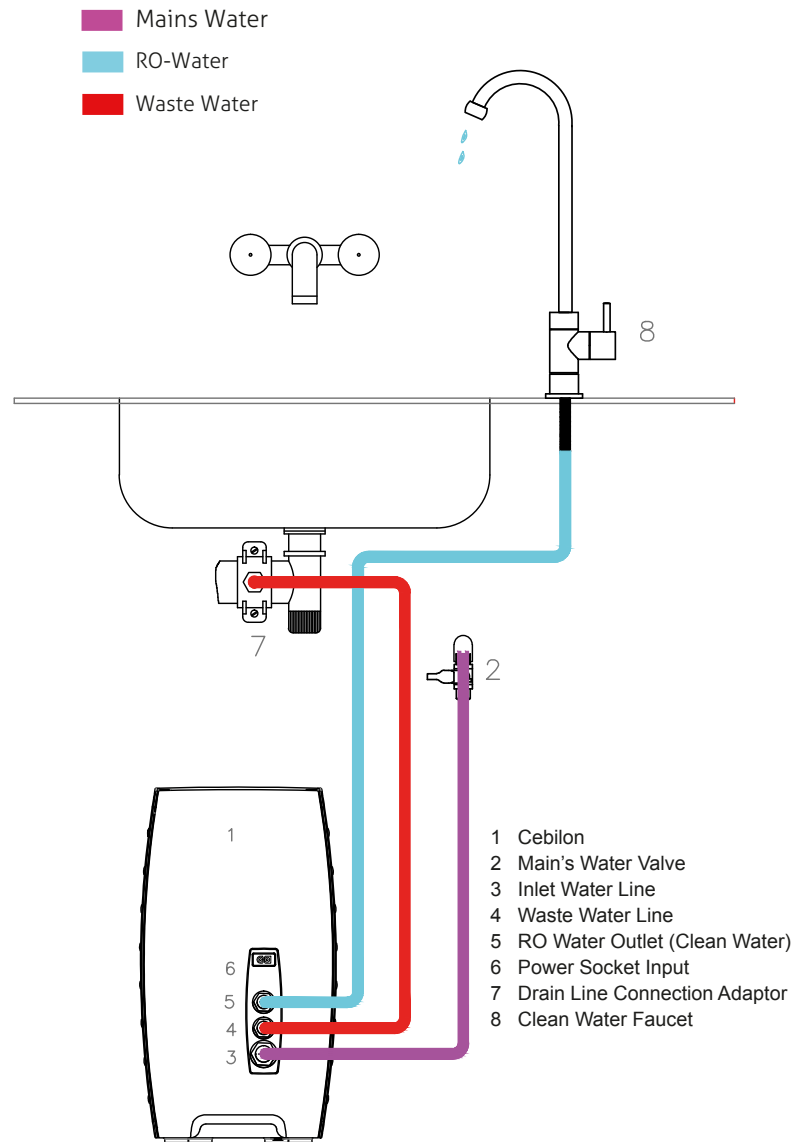

Figure 2. RO Installation Scheme

# Water Connection

- Close the mains water from the apartment inlet valve.
- After draining the water left in the pipes from proper places, mount the three-way adapter to the mains by ensuring the sealing.
- First, mount the 1/4" ball valve to the three-way adapter by wrapping a teflon tape in a position so that the valve is opened and closed easily (Figure 3.a).
- Connect the water inlet hose to the ball valve (Figure 3.b).
- Make sure the ball valve is closed (Figure 3.c).
- Open the mains water, check whether there is any leakage (Figure 3.d).
- Place the appliance on a suitable place underneath the counter in upright position.

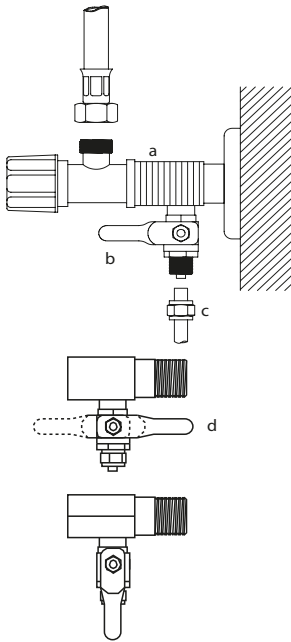
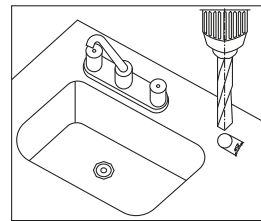

Figure 3. Water connection fittings

# Installing the faucet

Clean water faucet should be mounted carefully in terms of use and aesthetics. If the counter or kitchen sink will be drilled, drilling process should be proceeded after the dimensions are obtained so as to install the washers, nuts and unions under the counter or kitchen sink (Figure 4). Otherwise, drilling may be incorrect.

The location to be drilled may be granite, marble, concrete or stainless sink. If the counter is granite, it must be drilled with a 20 mm diameter bore bit. Bore bit is attached to the end of the drill and it is set to low speed. Water is poured on the ground to be drilled (do not drill without water). Bend the bore bit as 45 degrees and press slightly, it makes a trail on the granite. Then it is brought to an upright position slowly without lifting. When it reaches the upright position, drilling is completed by applying enough force. If the bore bit is not kept constant when we start drilling, parts can break off from the granite surface. The o-ring on the faucet's mirror cannot ensure sealing and may cause the water leakage down from the counter. Marble countertops can be drilled by the same drilling bit or bore bit. Concrete countertops are drilled with a contact tip and hammer drill. If concrete is coated with tiles, a pre drill is made with a small-diameter drill bit to avoid cracking the tiles. Bore bit for the stainless sinks is different.



- 1- Faucet Pipe
- 2- Faucet body
- 3- Handle
- 4- Hub cover
- 5- Faucet screw
- 6- Escutcheon plate
- 7- Tap oring
- 8- Bottom oring
- 9- Mounting washer
- 10- Compression nut
- 11- 1/4" ferrule
- 12- 1/4" Insert
- 13- Compression nut

Figure 4. Faucet

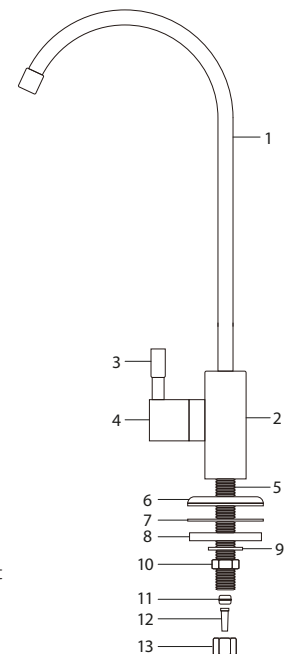

# Waste water connection Pre-tests

- If waste water pipe of the sink is not a throat hose but a 40 mm plastic pipe, it is mounted in a 1/4" clamp sealing sponge affixed state (Figure 5a).
- The flush is drilled from the hole of the clamp in 8 mm diameter on the same axis (Figure 5b). One end of the 1/4" waste water faucet is connected to this clamp and the other end is connected to the 1/4" waste water union.
- If waste water hose will be mounted on the 50 waste water installation, a 1/4" clamp will be mounted and the waste water hose will be mounted on its location above this. A seal must be used when mounting the adapter to the waste water installation.

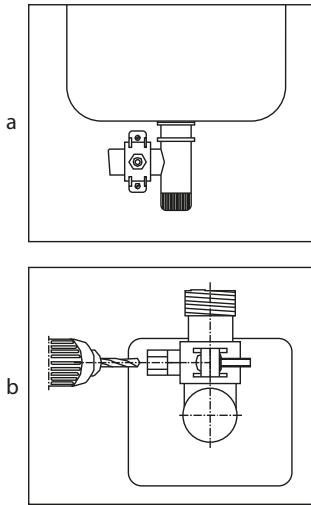

Figure 5. Waste water connection

- The adapter is plugged in after it is placed into the place where "36 V DC" is written on the appliance. In this case, it will not work due to lack of water and pressure in the system.
- Clean water faucet is turned on.
- Mains water is supplied to the system by opening the 1/4" ball valve (Figure 6). It is seen that the pump is running.
- The faucet is closed after a small amount of water flows from the clean water faucet.
- After the operation of the pump stops, leak test of all the connections in the system is performed.
- This system should be used after the twenty-four hours washing process, (Installation is done after this process is carried out by an authorized service.)

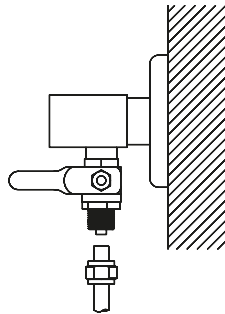

Figure 6. Mains inlet valve

# Points for Attention!

- The appliance is designed for domestic use. Parts such as storage tank, waste water hose, faucet must be attached indoor environment. Necessary measures should be taken to prevent freezing and waste water flow.
- Use the appliance after the necessary measures are taken in microbiologically unsafe or disinfected waters.
- The appliance must be supplied with its own power adapter.
- If the appliance will not be used for a long time (such as more than 1 month), the inlet water valve must be closed (figure 6), the adapter should be plugged out and the authorizes service must be called to disinfect the appliance when reactivating.
- When there not anyone in the house, close the water inlet valve of the appliance for safety purposes (Figure 6).
- The appliance must not be interfered for repair and maintenance purposes. Otherwise, it falls out of the warranty scope, these operations are carried out by Cebilon Authorized Service.
- As the inlet water temperature changes, the amount of clean water to be received and the efficiency may change. Therefore, water obtained may be low in winter and high in summer.
- In any unfavorableness (Figure 6) close the water inlet valve and consult Aura Cebilon Authorized Service.

# Maintenance

Maintenance of your appliance must be performed by an Authorized Service, appliances that of the maintenance is not performed by an Authorized Service will fall out of warranty.

The life of the filters used in Cebilon Dflow Reverse Osmosis System changes depending on various factors with the amount of water used. These major factors are inlet water quality, chlorine amount, residue amount etc. Filters are considered as supplies and they are out of warranty.

## Warning!

The ball valve in the appliance must be closed before the filter replacement. The pressure in the system is removed by opening the faucet of the appliance. Then, filter might be changed.

After the filter replacement process is completed, the ball valve must be opened.

DO NOT replace the filter, without closing tap water and removing the pressure in the appliance first.

# Recommended Filter Replacement Periods

Have timely periodic maintenance of your appliance to use your system efficiently and for longer time. The following replacement periods are the recommended durations for appliances used in mains water under normal conditions. The usage condition of your appliance may change depending on the properties of inlet water, amount of chlorine and sediment.

Our authorized services will perform periodic maintenance required for your system to work efficiently every six months.

Filter Type	Replacement Period	Duties
5 Micron Sediment Filter	6 months	Sediment filtration is performed by taking coarse particles in water. Clears the water at a micron level. Its life varies depending on the nature of the inlet water.
Carbon Filter	6-12 months	Keeps all the gas in water chemically in itself. The excess chlorine reduces the life of the carbon filter. Timely replacement protects from damage of chlorine and extends the life of the membrane filter.
1 Micron Sediment Filter	6-12 months	This filtration is performed by taking coarse particles in water. Clears the water at a micron level. Its life varies depending on the nature of the inlet water.
Mineralized Post Carbon Filter	6-12 months	Regulates the pH by supplying mineral to water. Filters bad odors that may have been left in the water.
1 <sup>st</sup> Membrane 400 GPD	36 months	This is where Reverse Osmosis occurs. Life of the filter will change depending on the ion concentration in the mains water, amount of the distilled water and whether the maintenance is carried out in a timely manner.
2 <sup>nd</sup> Membrane 400 GPD	24 months	

# Troubleshooting

PROBLEM	POSSIBLE CAUSES	RECOMMENDED SOLUTION
There are bubbles in the water or the water is milky coloured.	Air in the system.	Air in the system is a normal occurrence after initial installation. Sometimes, air caused by the mains may exist. This will return to normal after usage for a while. There is no inconvenience for using this water.
Low water flow from the appliance.	Pump is not operating and there is no sufficient pressure.	Check whether the pump adaptor is plugged in. If adaptor is plugged in, consult to your service.
	There is bending, crushing on the hoses.	Check all the hoses connected to the appliance, eliminate bendings, if any.
	Pre-filter group is clogged.	Please consult the service.
	Membrane does not perform well.	Please consult the service.
	Inlet water temperature dropped.	This is not a fault. Decrease in clean water is normal during winter.
	Check valve is defective.	Please consult the service.
The pump is running continuously.	High Pressure Switch may be defective.	Close the inlet water and consult to your service.
	Low Pressure Switch may be defective.	Close the inlet water and consult to your service.
	Check valve may be defective.	Please consult the service.
	Shut off valve may be defective.	
	Pump may be defective.	

# DIGITAL SCREEN FUNCTIONS

Press and hold the **ON/OFF** button for 3 seconds to switch the device **On/Off**.

- Each light indicates the service life of the respective filter.
- **GREEN LIGHT** illuminates continuously under normal operating conditions.
- **RED LIGHT** indicates that it is time to replace the 5 Micron Sediment, Activated Carbon, 1 Micron Sediment and Post Carbon filters.
- **RED LIGHT (MEMBRANE)** it indicates that it is time to replace the first membrane filter.
- **BLUE LIGHT (MEMBRANE)** it indicates that it's time to replace the second membrane filter.

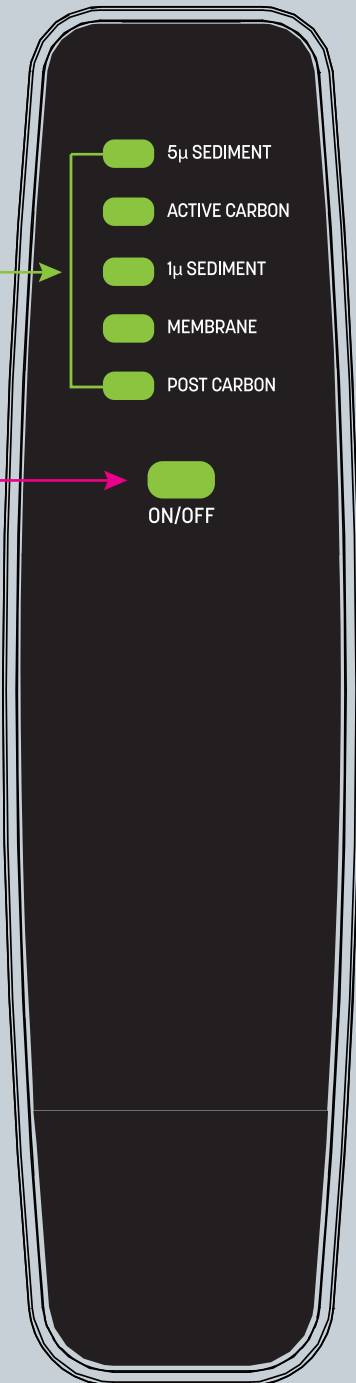
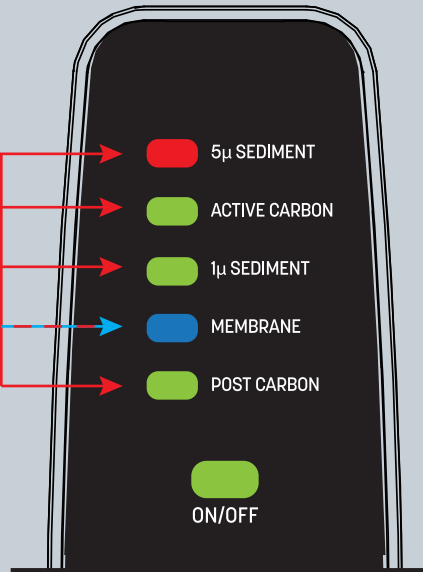



### **Complies with WEEE Regulation**

This symbol on the product or packaging shows that the product should not be disposed of with normal domestic waste and should be transmitted to the collection points for recycling the electrical and electronic appliances. If you dispose of this product correctly, you will be contributing to the protection of the nature and human health. Wrong disposal will be harmful to the nature and human health. You may find further information on recycling this product from your municipal, waste collection service or from the store you have purchased the appliance.

**ihlas**   
**Ev Aletleri**

BOSB Mermerciler San. Sitesi  
7. Cad. No: 14 Beylikdüzü - İstanbul  
Tel: 0212 875 35 62 Faks: 0212 875 36 64  
[www.iea.com.tr](http://www.iea.com.tr) - [info@iea.com.tr](mailto:info@iea.com.tr)

338017Z